

## Hardware Installation (In-Line)

1. Insert one end of the provided ethernet cable into the “P” port on the AR Data tool hardware and the other end into the customer’s device.
2. Plug the customer provided ethernet cable from the wall data port into the “N” port on the AR Data tool hardware.
3. Plug the Micro USB side of the provided USB power cord into the port on the AR Data Device and the USB-A end into the customer device, or use the supplied Micro USB Power Cable.

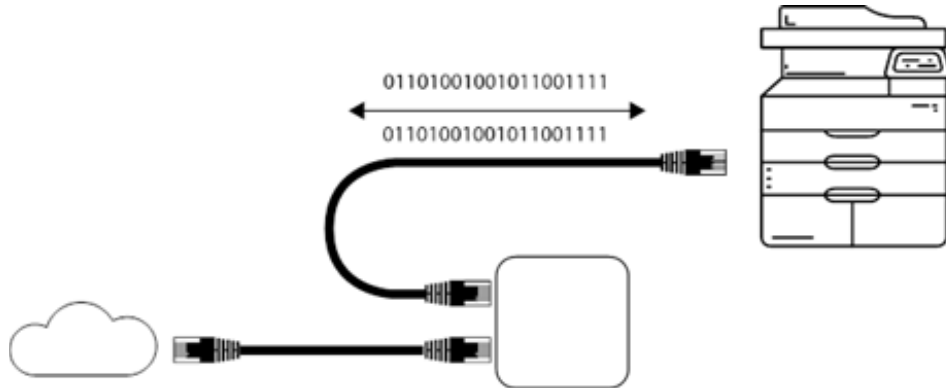

Note: Installation of the AR Data hardware tool can be done anywhere on the network and does not need to be installed in-line with the device.



## Register the Tool

1. Enter the registration information for the customer that the tool is being setup for. You will get this information from FMAudit®/Printanista™ where you download the installer.
2. Login to FMAudit® Central/Printanista™ and navigate to the customer the tool is for.
3. Click the Install DCA button to download the FMAudit® Onsite and in the operating system drop down, choose **Linux**.
4. Record the **'Activation PIN'** and **'Website URL'** information to use in configuring the tool.

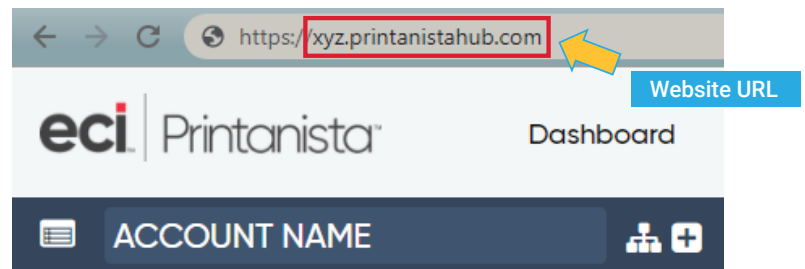
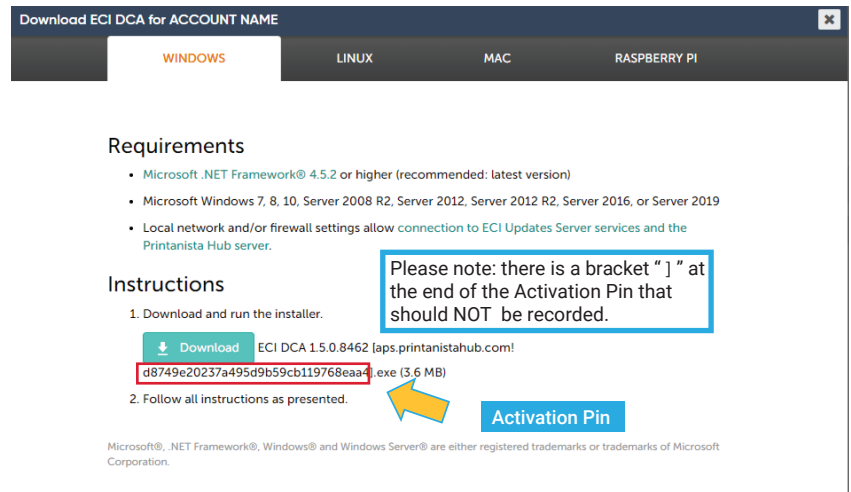

## Configure the Tool

1. To enter the registration information, navigate to the URL of the AR Data tool by entering the IP address of the AR Data tool (for example, **http://192.168.1.20**). This will bring up the AR Data splash page below.
2. Fill in the **'Website URL'** and customer's **'Activation PIN'**, information and press save.
3. On the next screen, select **'Submit'** to update the AR Data tool registration key. The AR Data tool will perform an automatic reboot.



## Need Support?

If you're having trouble with the AR Data hardware tool you can email [support@alwaysreportingdata.com](mailto:support@alwaysreportingdata.com).